

CURRENT SENSOR

PRODUCT SERIES: SFG-X.XP/S1

PRODUCT PART NUMBER: SFG-0.3P/S1, SFG-1.0P/S1

REVISION: Ver 1.1

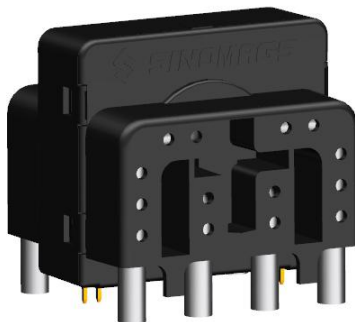

CONTENT

1.	Description.....	2
2.	Absolute parameter.....	3
3.	SFG-0.3P/S1 Electrical data.....	4
4.	SFG-1.0P/S1 Electrical data.....	5
5.	Application information.....	6
6.	Dimensions (in mm).....	7
7.	Assembly on PCB.....	8

1. Description

Features

- Open loop current transducer
- Voltage output
- Insulation voltage for 5kV/AC
- Single supply voltage
- PCB mounting.

Applications

- Residual current measurement
- Leakage current measurement in transformerless PV inverters
- First human contact protection of PV arrays
- Failure detection in power sources
- Leakage current detection in stacked DC sources
- Communication power

Advantages

- High accuracy
- High overload capability
- High insulation capability
- High separation ability
- Low temperature drift
- Degauss and test functions.

Standards

- EN 50178
- IEC 61326-1: 2012

Application Domain

- Industry.

2. Absolute parameter

Absolute maximum ratings

Parameter	Symbol	Unit	Value
Supply voltage	V _c	V	5.5
Primary conductor temperature	T _{B max}	°C	110
Overload capability (100 μs, 500 A/μs)	I _{P max}	A	3300
Maximum Primary current @ T _{Amax} =105°C	I _M	A/wire	80

Stresses above these ratings may cause permanent damage. Exposure to absolute maximum ratings for extended periods may degrade reliability.

Isolation parameters

Parameter	Symbol	Unit	Value	Remark
RMS voltage for AC test 50Hz/1 min	V _d	kV	5	
Impulse withstand voltage 1.2/50μs	V _w	kV	10.1	
Comparative tracking index	CTI	V	600	
Clearance distance (pri. –pri.)	d _{Cl}	mm	7.5	Shortest distance through air
Creepage distance (pri. –pri.)	d _{Cp}	mm	7.5	Shortest path along device body
Clearance distance (pri. –sec.)	d _{Cl}	mm	11	Shortest distance through air
Creepage distance (pri. –sec.)	d _{Cp}	mm	11	Shortest path along device body
Case material			V0 according to UL 94	

Environmental and mechanical characteristics

Parameter	Symbol	Unit	Min	Typ	Max	Comment
Ambient operating temperature	T _A	°C	-40		105	
Ambient storage temperature	T _S	°C	-45		125	
Mass	m	g		70		
standard	EN 50178, IEC 61010-1, UL 508					

3. SFG-0.3P/S1 Electrical data

SFG-0.3P/S1 at $T_A = 25^\circ\text{C}$, $V_C = 5\text{ V}$.

Parameters	Symbol	Unit	Min	Typ	Max	Remark
Primary nominal residual rms current	I_{pn}	A		0.3		
Primary residual current, measuring range	I_{pm}	A	-0.5		0.5	
Supply voltage	V_C	V	4.9	5	5.1	
Current consumption	I_C	mA		18		
Reference voltage @ $I_P = 0$	V_{ref}	V	2.475	2.5	2.525	Internal reference
Electrical offset voltage	V_{oe}	mV	-25		25	$(V_{out} - V_{ref})$ @ 0 A
Theoretical sensitivity	G_{th}	V/A		4		
Linearity error	ϵ_L	%		0.5	1	
Check current	I_{CK}	mA		50		$\pm 5\text{mA}$
Output voltage(Checkfunction)	V_{CK}	V		$V_{oe} + 0.2$		
Check enable voltage	V_{CE}	V	3.3		V_C	
Check disabled voltage	V_{CD}	V		< 0.2		
Frequency bandwidth (-3dB)	BW	Hz		700		
Noise(1 Hz ~ 10 kHz)	V_{no}	mV rms		10		
Accuracy@ $I_{PN}@T_A = 25^\circ\text{C}$	$X_{25^\circ\text{C}}$	% of I_{PN}		± 2		
Accuracy@ I_{PN} @ $T_A = 105^\circ\text{C}$	$X_{105^\circ\text{C}}$	% of I_{PN}		± 4		
Fault over current recovery limit	I_M	A		80		

4. SFG-1.0P/S1 Electrical data

SFG-1.0P/S1 at $T_A = 25^\circ\text{C}$, $V_C = 5\text{ V}$.

Parameters	Symbol	Unit	Min	Typ	Max	Remark
Primary nominal residual rms current	I_{pn}	A		1.02		
Primary residual current, measuring range	I_{pm}	A	-1.7		1.7	
Supply voltage	V_C	V	4.9	5	5.1	
Current consumption	I_C	mA		18		
Reference voltage @ $I_P = 0$	V_{ref}	V	2.475	2.5	2.525	Internal reference
Electrical offset voltage	V_{oe}	mV	-25		25	$(V_{out} - V_{ref})$ @ 0 A
Theoretical sensitivity	G_{th}	V/A		1.17		
Linearity error	ϵ_L	%		0.5	1	
Check current	I_{CK}	mA		170		$\pm 5\text{mA}$
Output voltage(Checkfunction)	V_{CK}	V		$V_{oe} + 0.2$		
Check enable voltage	V_{CE}	V	3.3		V_C	
Check disabled voltage	V_{CD}	V		< 0.2		
Frequency bandwidth (-3dB)	BW	Hz		700		
Noise(1 Hz ~ 10 kHz)	V_{no}	mV rms		10		
Accuracy@ $I_{PN}@T_A = 25^\circ\text{C}$	$X_{25^\circ\text{C}}$	% of I_{PN}		± 2		
Accuracy@ I_{PN} @ $T_A = 105^\circ\text{C}$	$X_{105^\circ\text{C}}$	% of I_{PN}		± 4		
Fault over current recovery limit	I_M	A		80		

5. Application information

Application circuit

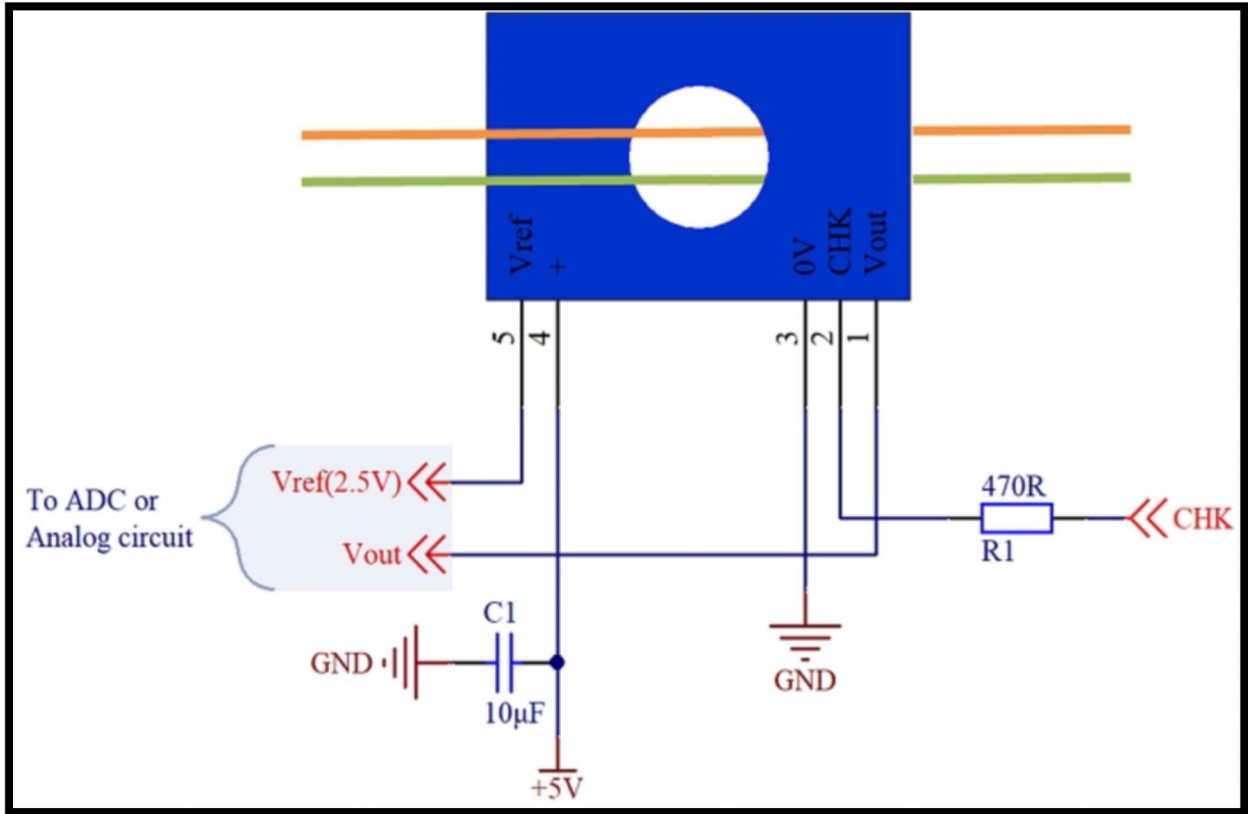

Self-check Function

Set the CHK pin to high status. SFG-X.XP/S1 will run in self-test mode, check the out pin, equivalent to the status I_p is I_{ck} , at this time the output has equal voltage, the detector is OK. Then sets CHK to low voltage $V_{CD} < 0.2V$, the SFG-X.XP/S1 starts to run in the residual current.

6. Dimensions (in mm)

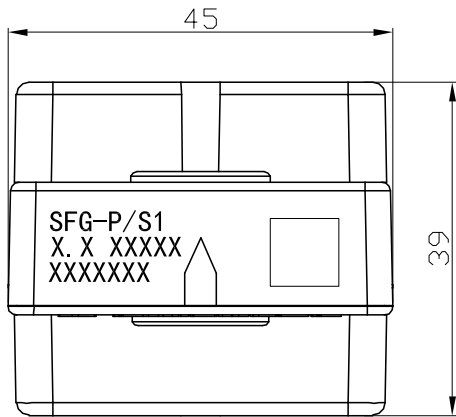

	D _{C1}	D _{CP}
B-C	13.4	—
A-C	7.5	>7.5
C-D	—	>14

D is secondary inside the transducer

On the customer's PCBA		
	D _{C1}	D _{CP}
B-C	11	11
A-C	4	4

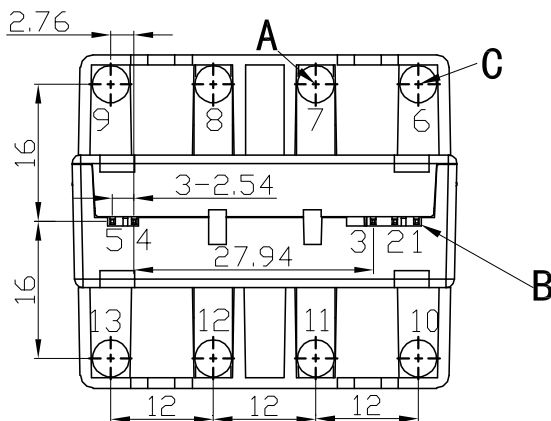
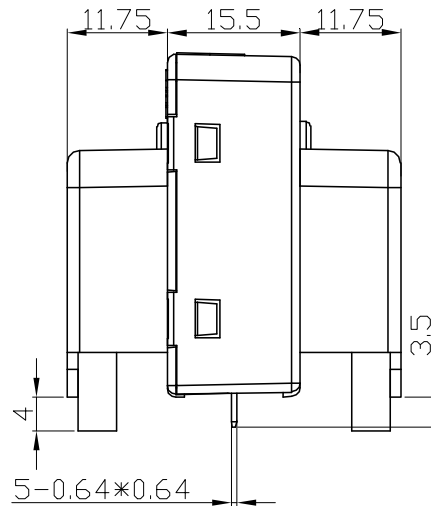
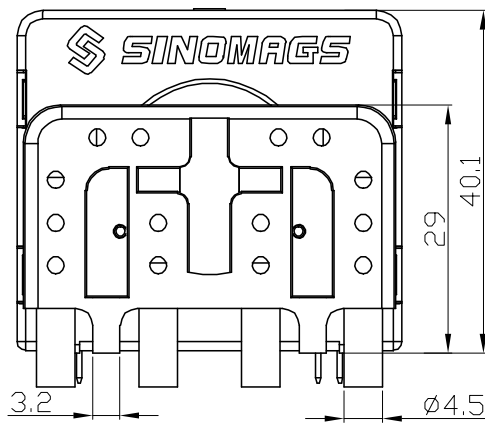

Terminals:

1	Vout	8	I _{p+}
2	CHK	9	I _{p+}
3	GND	10	I _{p-}
4	Vcc	11	I _{p-}
5	Vref	12	I _{p-}
6	I _{p+}	13	I _{p-}
7	I _{p+}		

Material : Fit UL94V-0 & RoHS requirements ;

General tolerance : ±0.5

Unit :mm

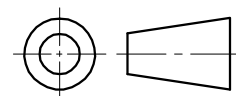

7. Assembly on PCB

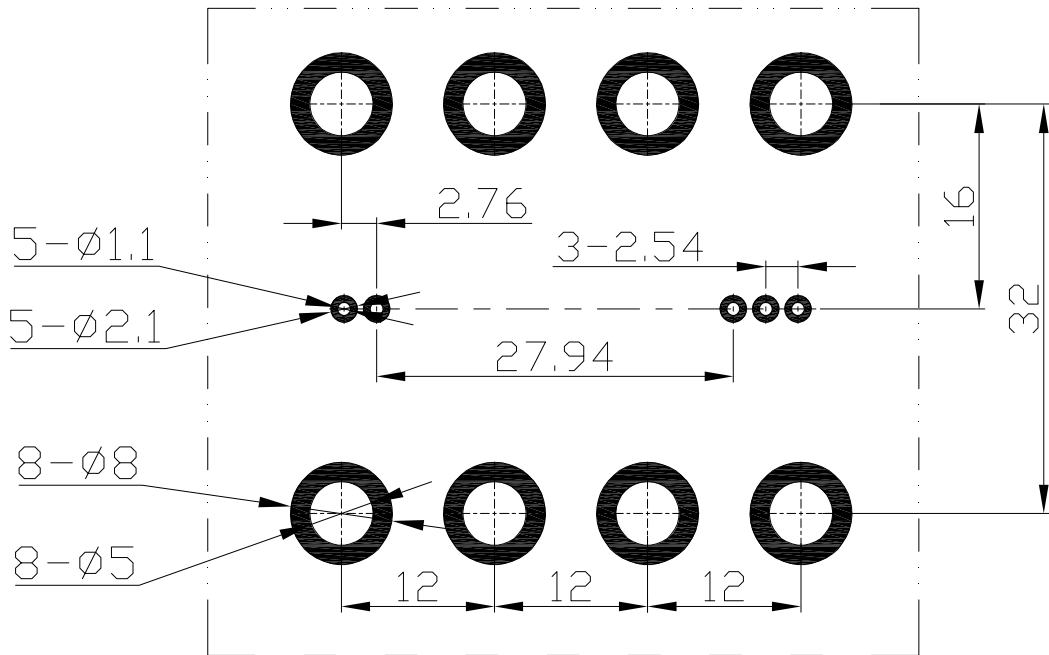

- Maximum PCB thickness 2.4 mm
- Wave-soldering: 260°C @ 10 s
- Recommended PCB hole diameter 1.2 mm for secondary pin.