

CURRENT SENSOR

PRODUCT SERIES: STB-LA/Zx

PRODUCT PART NUMBER: STB-100LA/Z, STB-100LA/ZN
STB-150LA/Z, STB-150LA/ZN
STB-200LA/Z, STB-200LA/ZN

VERSION: Ver 4.2

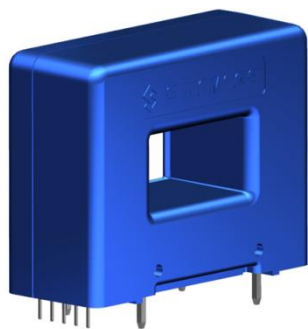

Sinomags Technology Co., Ltd.

Web site: www.sinomags.com

CONTENT

1.	Description.....	2
2.	Electrical parameters (STB-100LA/Z, STB-100LA/ZN).....	3
3.	Electrical parameters (STB-150LA/Z, STB-150LA/ZN).....	4
4.	Electrical parameters (STB-200LA/Z, STB-200LA/ZN).....	5
5.	Dimensions: STB-xxxLA/Z.....	6
6.	Dimensions: STB-xxxLA/ZN.....	7
7.	PCB footprint (STB-xxxLA/Z).....	8
8.	PCB footprint (STB-xxxLA/ZN).....	8

1. Description

STB-LA/Z series current sensors are based on close loop principle with TMR technology. The sensor can detect the current with DC, AC, pulse and irregular wave shape.

Typical application

- Solar inverter
- Direct-current dynamo
- Uninterruptible Power Supplies (UPS)
- Switched model power supplies (SMPS)
- Variable frequency converter

General parameters

Parameter	Symbol	Unit	Value	Remark
Working temperature	T_A	°C	-40 ~ 85	
Storage temperature	T_stg	°C	-40 ~ 85	
Mass	m	g	53	STB-200LA/ZN
Mass	m	g	TBD	STB-150LA/Z

Absolute parameters

Parameters	Symbol	Unit	Value
Supply voltage	Vcc_max	V	6
Maximum primary current	I_p_max	A	10*I_pn
ESD rating (HBM)	U_ESD_HBM	kV	4

Remark: the unrecoverable damage may occur when the product works on the conditions over the absolute maximum ratings. Long-time working on the absolute maximum ratings may cause the degradation on performance and reliability.

Isolation parameters

Parameter	Symbol	Unit	Value	Remark
RMS voltage for AC test 50Hz/1 min	Ud	kV	4	
Impulse withstand voltage 1.2/50μs	Ūw	kV	8	
Clearance distance (pri. -sec)	dCl	mm	12.9	Shortest distance through air
Creepage distance (pri. -sec)	dCp	mm	12.9	Shortest path along device body
Case material			V0	According to UL 94
Comparative tracking index	CTI	V	600	

2. Electrical parameters (STB-100LA/Z, STB-100LA/ZN)

Condition: Vcc = 5.0 V, RL = 10 kΩ, TA = 25°C, unless specified.

Parameters	Symbol	Unit	Min.	Typ.	Max.	Remark
Primary nominal rms current	I _{pn}	A		100		
Primary current measuring range	I _{pm}	A	-300		300	
Supply voltage	V _{cc}	V	4.75	5	5.25	
Consumption current	I _c	mA	15 + I _p /NS*1000			NS = 1500
Reference voltage	V _{ref}	V	2.48	2.5	2.52	
Electrical offset voltage	V _{oe}	mV		5		100 % tested (V _{out} – V _{ref})@ 0 A
Magnetic offset current	I _{om}	A	100		100	@6*I _{pn}
Full-scale voltage	V _{fs}	V		± 0.625		(V _{out} – V _{ref})@ I _{pn}
Theoretical sensitivity	G _{th}	mV/A		6.25		0.625 V @ I _{pn}
Sensitivity error	G _{err}	% of I _{pn}	-0.8		0.8	
Linearity error within I _{pn}	ξ _L	% of I _{pn}	-0.15		0.15	@25°C
Reaction time @ 10 % of I _p	t _{ra}	μs		0.3		
Step response time @ 90 % of I _p	t _r	μs		0.3		
-3 dB band width	BW	kHz		300		
Noise DC ~ 10 kHz DC ~ 100 kHz	V _{noise}	mVpp		5 6		
Accuracy @ 25°C	X	% of I _{pn}	-0.8		0.8	
Accuracy @ 85 °C	X _{TRange}	% of I _{pn}	-1.1		1.1	

3. Electrical parameters (STB-150LA/Z, STB-150LA/ZN)

Condition: $V_{cc} = 5.0\text{ V}$, $R_L = 10\text{ k}\Omega$, $T_A = 25^\circ\text{C}$, unless specified.

Parameters	Symbol	Unit	Min.	Typ.	Max.	Remark
Primary nominal rms current	I_{pn}	A		150		
Primary current measuring range	I_{pm}	A	-400		400	
Supply voltage	V_{cc}	V	4.75	5	5.25	
Consumption current	I_c	mA	$15 + I_p/NS*1000$			NS = 1500
Reference voltage	V_{ref}	V	2.48	2.5	2.52	
Electrical offset voltage	V_{oe}	mV		5		100 % tested ($V_{out} - V_{ref}$)@ 0 A
Magnetic offset current	I_{om}	mA	100		100	@ $6*I_{pn}$
Full-scale voltage	V_{fs}	V		± 0.625		($V_{out} - V_{ref}$)@ I_{pn}
Theoretical sensitivity	G_{th}	mV/A		4.167		0.625 V @ I_{pn}
Sensitivity error	G_{err}	% of I_{pn}	-0.8		0.8	
Linearity error within I_{pn}	ξ_L	% of I_{pn}	-0.15		0.15	@ 25°C
Reaction time @ 10 % of I_p	t_{ra}	μs		0.3		
Step response time @ 90 % of I_p	t_r	μs		0.3		
-3 dB band width	BW	kHz		300		
Noise DC ~ 10 kHz DC ~ 100 kHz	V_{noise}	mVpp		5 6		
Accuracy @ 25°C	X	% of I_{pn}	-0.8		0.8	
Accuracy @ 85°C	X_{TRange}	% of I_{pn}	-1.1		1.1	

4. Electrical parameters (STB-200LA/Z, STB-200LA/ZN)

Condition: Vcc = 5.0 V, RL = 10 kΩ, T A = 25°C, unless specified.

Parameters	Symbol	Unit	Min.	Typ.	Max.	Remark
Primary nominal rms current	I _{pn}	A		200		
Primary current measuring range	I _{pm}	A	-450		450	
Supply voltage	Vcc	V	4.75	5	5.25	
Consumption current	Ic	mA	15 + I _p */NS*1000			NS = 1500
Reference voltage	V _{ref}	V	2.48	2.5	2.52	
Electrical offset voltage	V _{oe}	mV		5		100 % tested (V _{out} – V _{ref})@ 0 A
Magnetic offset current	I _{om}	mA	-210		210	@10*I _{pn}
Full-scale voltage	V _{fs}	V		± 0.625		(V _{out} – V _{ref})@ I _{pn}
Theoretical sensitivity	G _{th}	mV/A		3.125		0.625 V @ I _{pn}
Sensitivity error	G _{err}	% of I _{pn}	-0.8		0.8	
Linearity error within I _{pn}	ξ _L	% of I _{pn}	-0.15		0.15	@25°C
Reaction time @ 10 % of I _p	t _{ra}	μs		0.3		
Step response time @ 90 % of I _p	t _r	μs		0.3		
-3 dB band width	BW	kHz		300		
Noise DC ~ 10 kHz DC ~ 100 kHz	Vnoise	mVpp		5 6		
Accuracy @ 25°C	X	% of I _{pn}	-0.8		0.8	
Accuracy @ 85 °C	X _{TRange}	% of I _{pn}	-1.4		1.4	

5. Dimensions: STB-xxxLA/Z

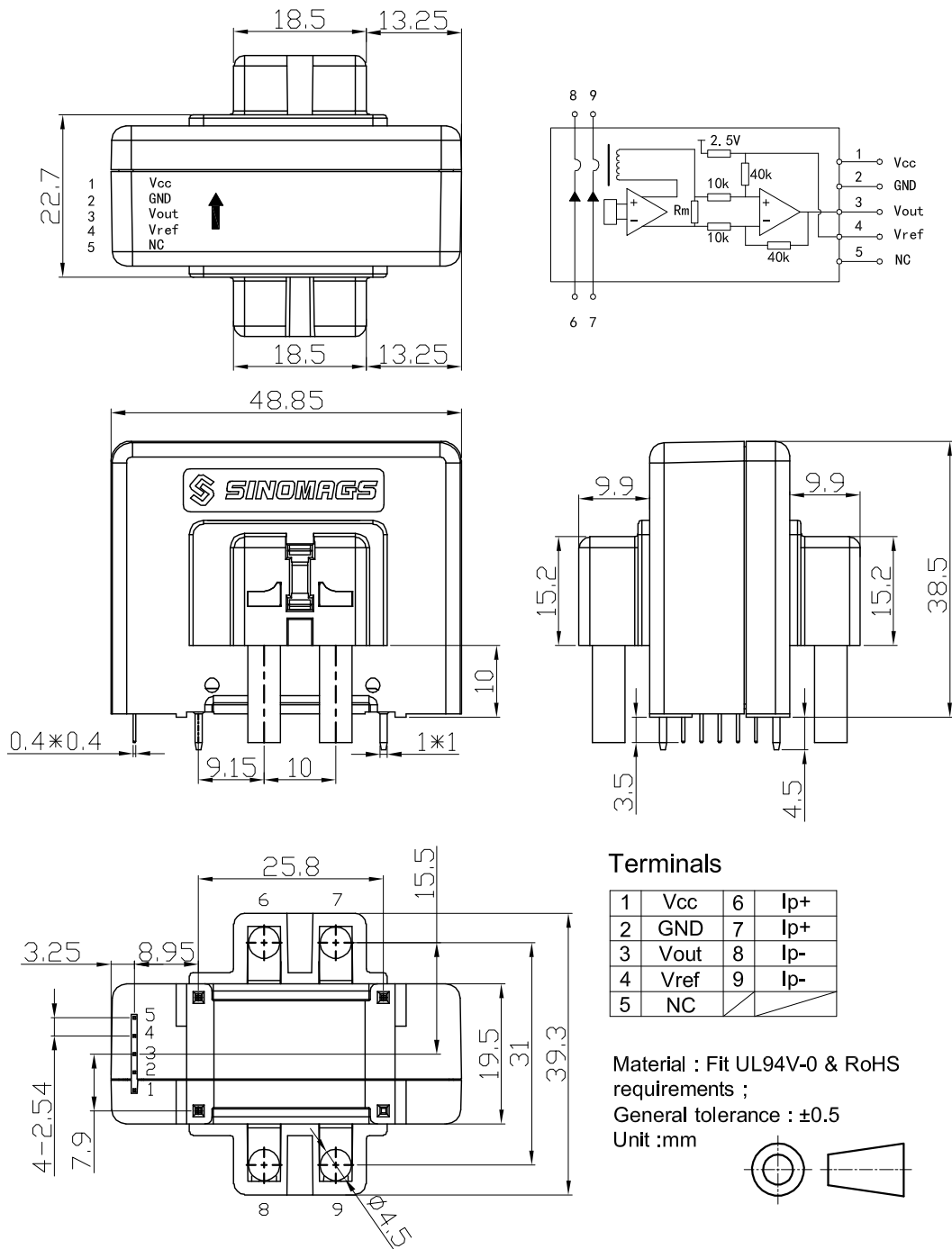

6. Dimensions: STB-xxxLA/ZN

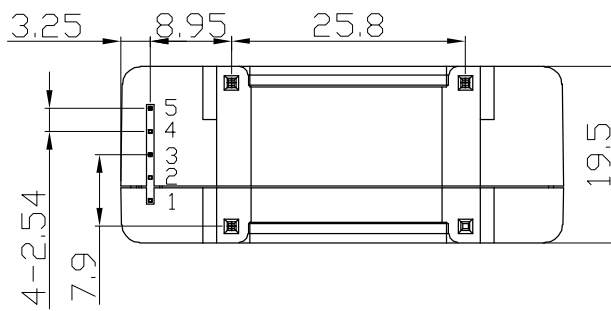
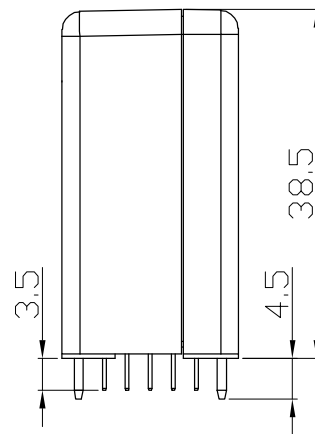
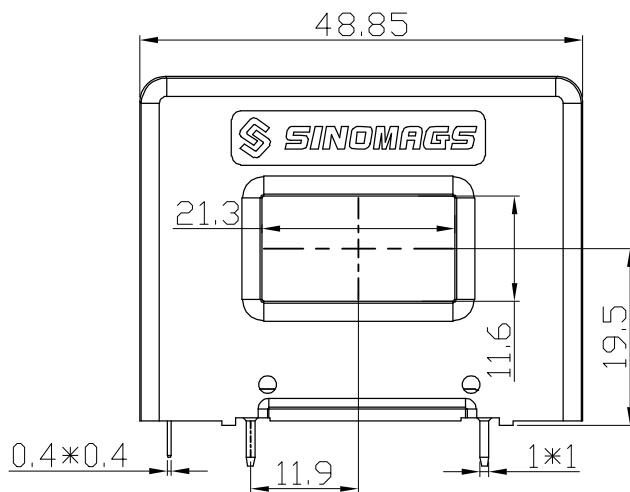
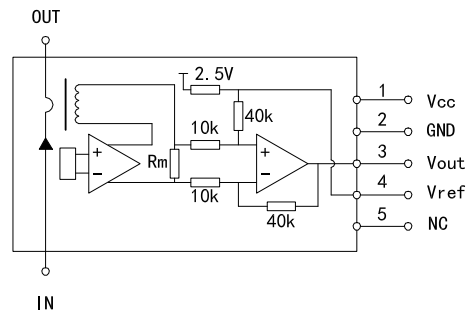
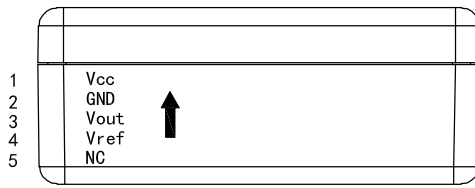

Terminals

1	Vcc
2	GND
3	Vout
4	Vref
5	NC

Material : Fit UL94V-0 & RoHS requirements ;

General tolerance : ± 0.5

Unit :mm

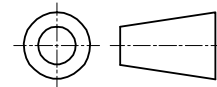

7. PCB footprint (STB-xxxLA/Z)

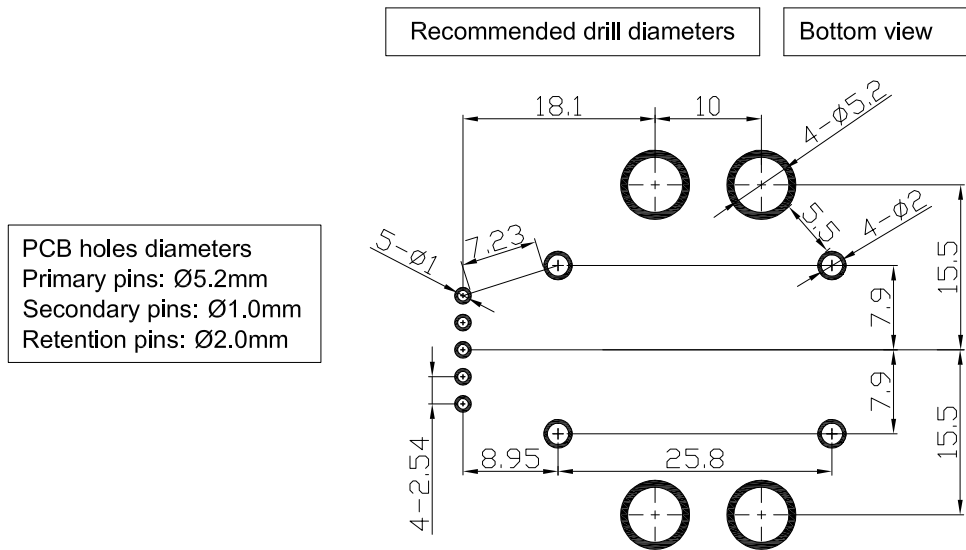

Assembly on PCB

- Recommended PCB hole diameter: 1 mm for secondary pins, 2 mm for retention pin.
- Maximum PCB thickness: 2.4 mm (can be customized per request).
- Wave soldering profile: maximum 260°C for 10 seconds.

8. PCB footprint (STB-xxxLA/ZN)

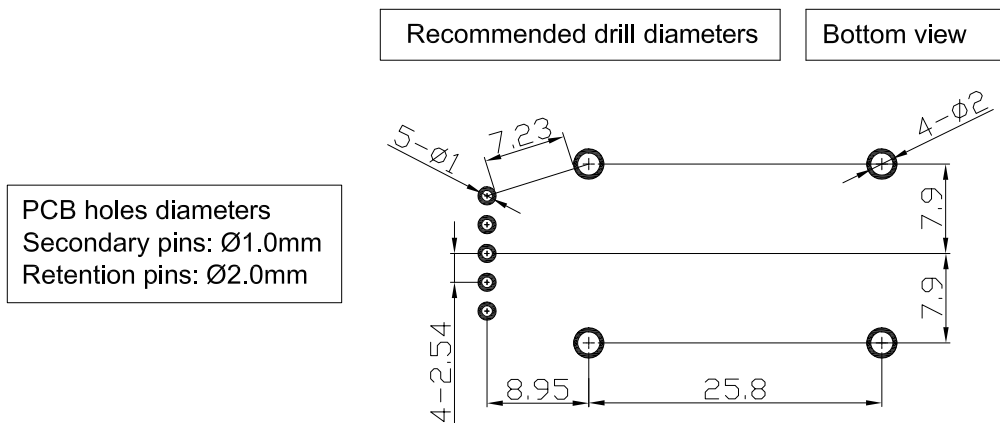

Assembly on PCB

- Recommended PCB hole diameter: 1 mm for secondary pins, 2 mm for retention pin.
- Maximum PCB thickness: 2.4 mm (can be customized per request).
- Wave soldering profile: maximum 260°C for 10 seconds.