

CURRENT SENSOR

PRODUCT SERIES: STB-300LA/M

PRODUCT PART NUMBER: STB-300LA/M

VERSION: Ver 1.1



Sinomags Technology Co., Ltd.

Web site: www.sinomags.com

CONTENT

1. Description.....	2
2. Electrical parameters (STB-300LA/M).....	3
3. Dimensions: STB-300LA/M.....	4
4. PCB footprint (STB-300LA/M).....	5

1. Description

STB-300LA/M series current sensors are based on close loop principle with TMR technology. The sensor can detect the current with DC, AC, pulse and irregular wave shape.

Typical application

- Solar inverter
- Direct-current dynamo
- Uninterruptible Power Supplies (UPS)
- Switched model power supplies (SMPS)
- Variable frequency converter

General parameters

Parameter	Symbol	Unit	Value	Remark
Working temperature	T_A	°C	-40 ~ 105	105°C, I _{max} =530A
Storage temperature	T_stg	°C	-40 ~ 105	
Mass	m	g	115	STB-300LA/M

Absolute parameters

Parameters	Symbol	Unit	Value
Supply voltage	V _{cc_max}	V	6
Maximum primary current	I _{p_max}	A	10*I _{pn}
ESD rating (HBM)	U_ESD_HBM	kV	4
High temperature and humidity	T_HAST	-	85°C&85%RH (1000h)

Remark: the unrecoverable damage may occur when the product works on the conditions over the absolute maximum ratings. Long-time working on the absolute maximum ratings may cause the degradation on performance and reliability.

Isolation parameters

Parameter	Symbol	Unit	Value	Remark
RMS voltage for AC test 50Hz/1 min	U _d	kV	4	
Impulse withstand voltage 1.2/50μs	Ū _w	kV	8	
Case material			V0	According to UL 94
Comparative tracking index	CTI	V	600	

2. Electrical parameters (STB-300LA/M)

Condition: Vcc = 5.0 V, RL = 10 kΩ, T A = 25°C, unless specified.

Parameters	Symbol	Unit	Min.	Typ.	Max.	Remark
Primary nominal rms current	I _{pn}	A		300		
Primary current measuring range	I _{pm}	A	-600		600	
Supply voltage	V _{cc}	V	4.75	5	5.25	
Consumption current	I _c	mA	10 + I _p /NS*1000			NS = 1875
Reference voltage	V _{ref}	V	2.48	2.5	2.52	
Electrical offset voltage	V _{oe}	mV		5		100 % tested (V _{out} - V _{ref})@ 0 A
Magnetic offset current	I _{om}	mA	100		100	@6*I _{pn}
Full-scale voltage	V _{fs}	V		± 0.9375		(V _{out} - V _{ref})@ I _{pn}
Theoretical sensitivity	G _{th}	mV/A		3.125		0.9375 V @ I _{pn}
Sensitivity error	G _{err}	% of I _{pn}	-0.8		0.8	
Linearity error within I _{pn}	ξ _L	% of I _{pn}	-0.15		0.15	@25°C
Reaction time @ 10 % of I _p	t _{ra}	μs		0.3		
Step response time @ 90 % of I _p	t _r	μs		0.3		
-3 dB band width	BW	kHz		300		
Noise DC ~ 10 kHz DC ~ 100 kHz	V _{noise}	mVpp		5 6		
Accuracy @ 25°C	X	% of I _{pn}	-0.8		0.8	
Accuracy @ 85 °C	X _{TRange}	% of I _{pn}	-1.1		1.1	

3. Dimensions: STB-300LA/M

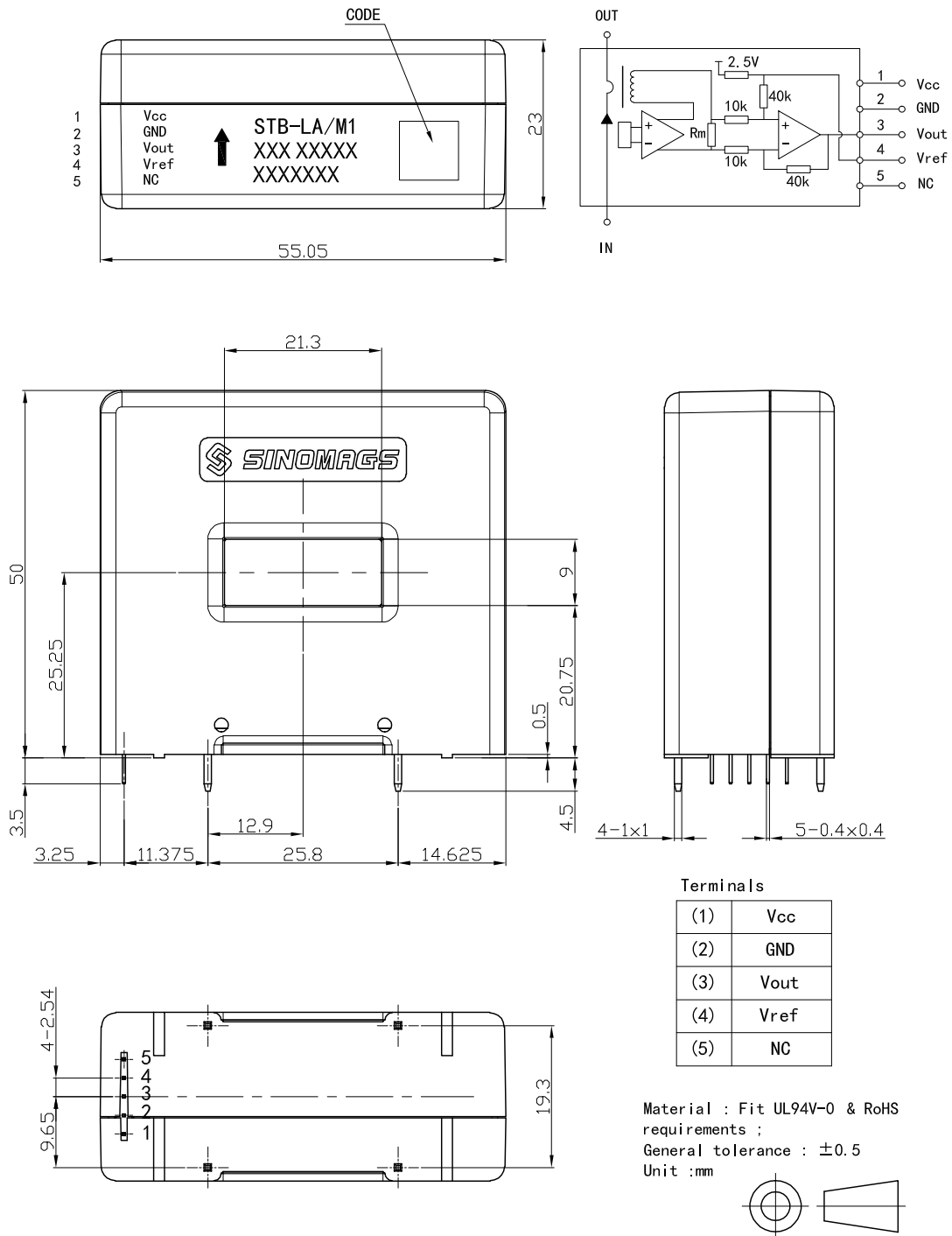

4. PCB footprint (STB-300LA/M)

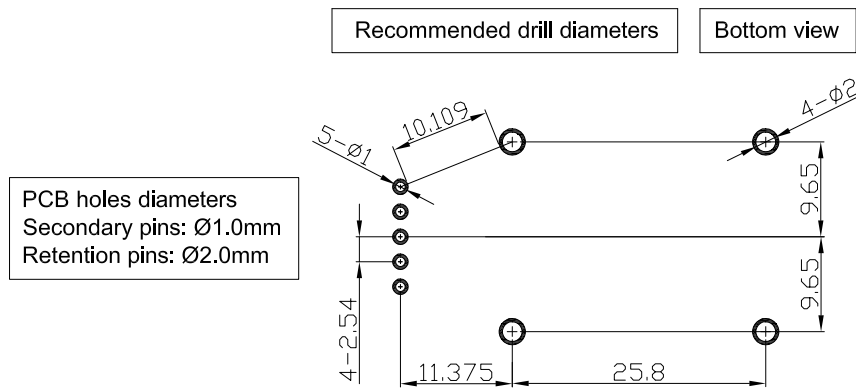

Assembly on PCB

- Recommended PCB hole diameter: 1 mm for secondary pins, 2 mm for retention pin.
- Maximum PCB thickness: 2.4 mm (can be customized per request).
- Wave soldering profile: maximum 260°C for 10 seconds.